

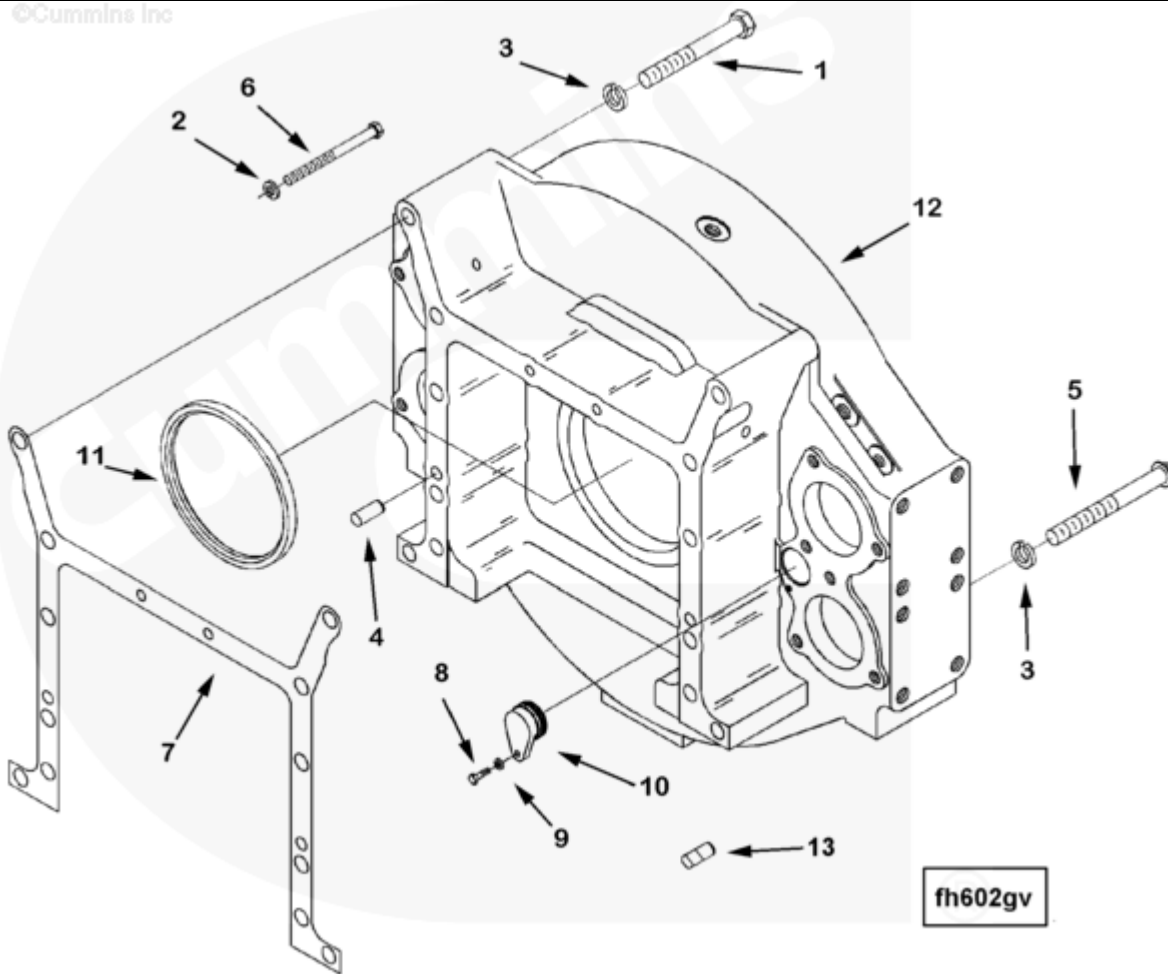

Parts Catalog - Option Detail

Electronic Parts Catalog - Option Detail				
Option	Group	Graphic	Film Card	Date
FH6024-02	16.01	fh602gv	K38	08-MAY-01
Engines	GTA38, K38, KTA38GC CM558, QSK38 CM2150 K106, QSK38 CM2150 MCRS, QSK38 CM850 MCRS			



[SMALL](#) | [MEDIUM](#) | [LARGE](#)

Cart	Ref No	Part Number	Part Description	Required	Remarks
View My Cart					
		FH6024-02	Flywheel Housing		SAE no. '0' flywheel housing...(More)
					for dry application. Housing
					has 5/8-18 and 3/4-16 tapped
					holes for mounting magnetic

					pick-up. Cannot be used with
					rear hydraulic pump drive
					option.
<input type="checkbox"/>	1	S 150 A	Hexagon Head Cap Screw	10	3/4 - 10 x 6 in.
<input type="checkbox"/>	2	S 610	Lock Washer	2	7/16 in.
<input type="checkbox"/>	3	S 611	Lock Washer	12	3/4 in.
<input type="checkbox"/>	4	70662	Pin Dowel	1	
<input type="checkbox"/>	5	205565	Twelve Point Cap Screw	2	3/4 - 10 X 7 Inch.
<input type="checkbox"/>	6	3176465	Hexagon Head Cap Screw	2	7/16 - 14 X 5 1/2 Inch.
<input type="checkbox"/>	7	3630874	Flywheel Housing Gasket	1	
<input type="checkbox"/>	8	S 167 A	Hexagon Head Cap Screw	2	1/4 - 20 X 7/8 in.
<input type="checkbox"/>	9	S 600	Lock Washer	2	1/4 in.
<input type="checkbox"/>	10	3010410	Access Hole Cover	2	
<input type="checkbox"/>	11	3630681	Oil Seal	1	
<input type="checkbox"/>	12	3176637	Flywheel Housing	1	
<input type="checkbox"/>	13	3634269	Diamond Dowel	1	